

XX. *The Limiting Thickness of Liquid Films.*

By A. W. REINOLD, M.A., *Professor of Physics in the Royal Naval College, Greenwich,*  
and A. W. RÜCKER, M.A., *Professor of Physics in the Yorkshire College, Leeds.*

*Communicated by R. B. CLIFTON, M.A., F.R.S., Professor of Experimental  
Philosophy in the University of Oxford.*

Received March 6,—Read April 19, 1883.

[PLATE 47.]

THE experiments described in this Paper are an extension of our previous investigations on the properties of liquid films. The interest and the difficulty of such inquiries increase as the thickness of the films diminishes, and culminate when they are sufficiently thin to show the black of the first order of NEWTON'S rings. We can in that case only infer from the colour that the thickness is less than a certain possible maximum. Our knowledge as to the real value of this maximum is, we venture to think, very uncertain, but it furnished, we believe, previous to our own investigations, the only clue to the thickness of a black liquid film.

In a Paper on the "Thickness of Soap Films" (Proc. Roy. Soc., 1877, No. 182, p. 345), we were however able to show, for the particular liquid and apparatus used:—

- i. That the variations in thickness of the black portions of the films were but a small fraction of that thickness.
- ii. That the thickness was independent of the breadth of the black ring.
- iii. That it was also independent of the thickness of that portion of the film which appeared to the naked eye to be in immediate contact with it.

We also proved, on the assumption that the specific resistance of the liquid in the film was identical with that of the same liquid in mass, that the average thickness of the black films observed must have been  $12 \times 10^{-6}$  millims.

In a more recent Paper (Phil. Trans., 1881, p. 447) we have shown that this assumption is correct for thicknesses greater than  $374 \times 10^{-6}$  millims., below which the number of our observations was insufficient to enable us to arrive at a reliable conclusion. It was also shown that very slight changes in the temperature or hygrometric state of the air produce great variations in the composition of films formed of a mixture of soap solution and glycerine.

MDCCLXXXIII.

4 0

In order, therefore, to investigate further the properties of very thin films, it was necessary that the temperature and hygrometric state of the air in contact with the films should be more completely under control. An apparatus by which this end is obtained has been devised, and we have with it repeated our observations on the electrical resistance of black soap films, with all the advantages gained by the use of the electrometer instead of the galvanometer which was previously employed (see Phil. Trans., 1881, p. 457). These experiments were sufficient to test the constancy of the thickness of black films, but would not alone afford a trustworthy measure of its absolute value. If NEWTON'S value of the thickness corresponding to the beginning of the black be accepted as correct, a black film must be at least ten times thinner than the thinnest for which we have directly proved that the specific resistance is the same as that of the liquid in mass. It was therefore uncertain whether the physical properties of films of such different thicknesses were the same, and it was necessary to check by some independent method the absolute thicknesses deduced from the electrical experiments. The thickness of a single black film is indeed so small that it is probably impossible to measure it by any direct optical method. We have, however, succeeded in determining optically the average thickness of a number of such films, and have thus obtained the required independent confirmation of the results of the electrical observations.

We propose therefore to describe (1) the electrical, (2) the optical experiments, and finally to compare the results with each other, and with those already referred to which were obtained some years ago.

### I. *Electrical experiments.*

The liquid employed in the experiments of which we have already published a description, was invariably PLATEAU'S *liquide glycérique*, to which was added 3, 5, or 7 per cent. of potassium nitrate. This liquid is admirable for many purposes. Films made with it are very persistent, thus allowing long continued observations to be made upon them, but they cannot always be depended upon to thin so far as to exhibit the black of the first order. Sometimes the black appears, and extends to a distance of two or three millimetres, or even more; at other times no trace of black is seen after several hours. We have not on any subsequent occasion been able to secure with a *liquide glycérique* a formation of black at all comparable in extent with that obtained in several of the experiments described in our first Paper above referred to. It was necessary for our purpose to discover a liquid from which films could be made possessing the two-fold property of persisting and of becoming black with tolerable regularity. Moreover, the black must extend to a distance of at least 11 millims. from the top, to admit of observations of any value being made upon it by the electrometer method. Experiments extending over many months were carried out with the object of discovering such a liquid, and a number of different solutions were

examined, consisting of mixtures of glycerine, water and oleate of soda in varying proportions, potassium nitrate being in all cases added to increase the conductivity. It was found at last that a plain soap solution not containing any glycerine answered the purpose best, and the solution employed in the experiments about to be described had the following composition :—

	Grammes.
Oleate of soda . . . . .	1·44
Potassium nitrate . . . . .	2·88
Distilled water . . . . .	100

*Specific resistance.*—The specific resistance of the soap solution was determined by the method described in our previous paper (Phil. Trans., *loc. cit.*).

At 12° C the specific resistance was 43·9 ohms per centimetre cube.

15	„	„	40·8	„	„
18·8	„	„	37·0	„	„

We may therefore assume without important error the specific resistance at the temperatures :—

	13°	14°	15°	16°	17°	18°
to be	43	42	41	40	39	38

*Refractive index.*—The refractive index of the solution was 1·337 at the temperature 16° C.

*Description of the apparatus.*—The apparatus constructed for us by Messrs. ELLIOTT Bros. is represented, half size, in Plate 47, fig. 1. It consists of a box made of thick glass plates, bevelled at the edges, and cemented together. The internal dimensions are 10 centims. square by 16·25 centims. high. The lid is a glass plate 11·4 centims. square, which closes the box airtight by means of a little grease. To it are attached all the essential parts of the apparatus. The lid with its fittings is shown in plan in fig. 3.

The soap film is supported between two platinum cylinders B and F (fig. 1), each 32·5 millims. in diameter. B is screwed to the end of a brass tube A, with a rack running along its length, which passes through a hole in the centre of the lid. It can be raised or lowered by means of a pinion C (figs. 1 and 3). That part of it which extends above the lid is enclosed in a larger tube in such a way that it can be moved up or down without establishing any connexion between the inside of the box and the outer air. D is a brass rod terminating below in a stout platinum wire E, which is bent at right angles and carries the short cylindrical ring F, perforated with holes. The rod D passes through an ebonite sheath G cemented to the lid. H is an ebonite milled head by which the ring F can be moved laterally as well as up and down.

The needles are supported in the following manner :—J is a brass tube accurately fitting the ebonite sheath, K, and terminating in a milled head, L. It supports a rectangular

prism of ebonite, through which pass two straight gold wires, the so-called needles. The extremities of the latter are soldered to fine insulated copper wires, which pass through a hole in the tube, seen at N, and are connected at the top of the tube to the binding screws, *c, c*. A glass shield, cemented to the ebonite clip P, and perforated with holes through which the needles pass without touching the glass, is employed to protect the pillar which supports the needles from the spray caused by bursting of the films. The tube J can not only be turned about its own axis, but the hole through which the sheath K passes being slotted, as shown at W, fig. 3, can be moved to and fro parallel to itself to a limited extent. By these means the needles can be inserted in the film in any suitable position. Only two needles are represented in the figure. There were three, but as a rule two only were used. *a* and *b* are binding screws for connecting the upper and lower supports of the film respectively with the circuit.

On the left of figs. 1 and 3, and in fig. 2 is shown the arrangement for saturating the inside of the box with moisture. It consists of an endless strip of linen O, passing over an ebonite roller Q, and kept stretched by an ebonite roller R below, the latter being weighted by a core of lead. The frame S carrying the strip can be raised or lowered by means of a nut T working on a screw fastened to the frame, and thus the linen can always be made to touch the liquid with which the bottom of the box is covered. The bevelled wheels seen at U, and the screw-head V, show how the upper roller is rotated so as to bring all parts of the linen in succession in contact with the liquid. The strip becomes elongated when wet, but by the nut T it can be drawn up to a suitable height. All the fittings connected with this part of the apparatus are of ebonite.

The hair hygrometer and the thermometer are not shown in fig. 1. They are supported on a single frame which is attached to the lid at Z, fig. 3. X is a plug closing a hole through which the liquid is introduced into the box.

To ensure constancy of temperature the film-box was placed in the centre of a glass tank full of water at the temperature of the room. The tank is made of thick glass plates, bevelled at the edges and cemented together. It is 30 centims. high by 25 centims. square. In the centre of it is fitted a square glass case of the same height as the tank, open top and bottom, and just large enough in cross section to allow the film-box to slide into it down to a fixed support. When the film-box is in its place it is surrounded by 7.5 centims. of water on every side except top and bottom. It was necessary to leave the top exposed in order to be able readily to move the needles or the linen strip, but the space underneath was filled up with cotton wool. By these means the temperature inside the film case can be maintained constant for many hours together.

The principle of the method of investigation employed was the same as that adopted in our previous experiments. A current from a battery of 9 LECLANCHÉ cells was passed through a film from top to bottom, and also through a box of

resistance coils containing a resistance of one megohm. The binding screws forming the terminals of this resistance could be connected with the electrometer. The gold needles could also be connected with the electrometer. Thus the difference of potential between the two needles in the film could be compared with that between two other points in the same circuit separated by a known resistance, and the resistance of the film between the two needles thence determined. The independent difference of potential between the needles, when they were in the film, but when no current was passing, was troublesome, but was reduced to a minimum by carefully cleaning them with nitric acid at the beginning of each day's work. Every part of the circuit was carefully insulated, and the insulation of the two gold needles was specially tested at the end of each set of observations. If the result of the test was not satisfactory, the preceding observations were discarded. In the case of no experiment given below did the insulation-resistance of the needles fall below 300 megohms.

The observations were carried out in the following manner. The glass case having been thoroughly cleaned and the hygrometer adjusted to stand at from  $40^{\circ}$  to  $50^{\circ}$  on the scale, when in a saturated space, the cover with its fittings was introduced into its place, and the apparatus thus enclosed was placed in the centre of the glass water-tank. The ebonite plug X, fig. 3, was then removed, a tube terminating in a small funnel introduced, and about 20 centims. of the soap solution poured in. This quantity was sufficient to cover the bottom of the box to a height of about 3 or 4 millims. The tube was withdrawn and the plug replaced. The screw-head V was then rotated so as to bring every part of the endless band into the liquid. This operation was subsequently repeated from time to time to ensure the linen remaining thoroughly wet. The apparatus was then left to itself for 30 or 40 minutes, which interval was as a rule sufficiently long to allow the hygrometric state to become constant. The hygrometer index rose at first rapidly and afterwards more slowly to a limiting position which it steadily maintained. On one occasion the indication was observed at intervals during 36 hours, and did not vary more than a tenth of a scale division. The new apparatus has, in fact, enabled us to overcome the chief difficulties encountered with the old. We can now maintain the temperature and hygrometric state of the space round the film constant as long as we wish. To proceed:—The electrical connexions having been completed, the lower ring F was turned to one side by the button H, and the pinion C rotated until the mouth of the upper cup just touched the liquid. When it was raised, a plane film was formed over its mouth, and this, after the ring F was restored to its position, was blown out into a cylinder in the usual way. The needles were inserted in the film and adjusted so that their position could be easily observed by the cathetometer. The length of the cylindrical film was usually about 34 or 35 millims., and the upper needle was placed about 5 millims. below the cup B. The distance between the points where the needles pierced the film varied in different experiments between 4.6 and 5.3 millims. There were, indeed, as has been stated, three needles on the same support, but only the first and second were

used, the third being bent on one side and not touching the films. On one occasion, however, the first and third needles were used, the middle one being bent back.

A mass of liquid having the form of a distorted circle, with its longer axis vertical, formed around each needle at the point where it entered the film. The horizontal wire of the cathetometer telescope was made to touch this circle at the top and bottom, and the mean reading was taken as that proper to the needle. The ratio between the mean diameter of these liquid masses and their distance apart was a necessary datum in applying a correction to the direct results. This correction was necessitated by the fact that the equipotential lines, which in the undisturbed film are horizontal circles, are distorted in the neighbourhood of the liquid masses formed by the insertion of the needles.

If  $a$  be the mean radius of these circles of liquid,  
 $b$  their distance apart,

then calculation shows that the observed resistance of the film between the needles must be increased by the following percentages:—

If  $\frac{b}{a} = 6, 7, 8, 9, 10$   
 percentage to be added = 6.1, 4.3, 3.4, 2.6, 2.2.

The films, although they were all made from the same solution and thinned under apparently identical conditions, behaved very differently one from another. Sometimes a ring of black was seen to form a few minutes after the film was blown, and to extend rapidly downwards. At other times half an hour elapsed before any black appeared. The passage of the electric current has a considerable effect in retarding the initial formation of the black, and sometimes prevents it altogether. When the black is once formed, the passage of the current appears sometimes to check its growth, but this effect is not always observed. As a rule the circuit was not completed until the film was in a condition suitable for electrical measurements, or, in other words, until the black had extended to a distance of 1.5 or 2 millims. below the second needle. Few films reached this stage, and we considered ourselves fortunate if in a day's work we succeeded in making trustworthy observations on a single film. If the black reached the second needle it not unfrequently continued to spread far below. On three or four occasions the film became black from top to bottom, a distance of 34 millims. The phenomenon of a cylindrical soap film, 32.5 millims. in diameter and 34 millims. long, black throughout its entire area, is a very remarkable one. Under these circumstances, so little light is reflected from any part of the film, that it is difficult to say at first sight whether a film is present or not.

The following table (Table I.) contains the results of our observations of 13 films. No results have been omitted from the table excepting such as we knew to be affected with error owing to defective insulation of the needles or other causes.

TABLE I.

Date and number of film.	Temperature.	Distance between needles.	Mean radius of liquid mass round each needle.	Number of observations from which the result is derived.	Length of <i>black</i> when film broke.	Time the film lasted.	Time occupied in electrical observations.	Resistance of <i>black</i> (ohms per millim.).	Percentage to be added.	Resistance corrected for disturbance of equipotential lines. †	Resistance of liquid in mass at temperature of observation (ohms per c.c.).	Thickness of <i>black</i> (10 <sup>-6</sup> millims.).
	°	millims.	(a) millim.		millims.	minutes.	minutes.					
1882.												
Dec. 21, III.	14.5	4.95	0.6*	6	14	35	15	320,600	3.0	330,200	41.5	12.31
" 26, III.	14.2	4.82	0.6*	8	27	..	..	299,000	3.4	309,200	42.0	13.30
" 26, IV.	14.5	4.65	0.6*	5	Throughout	..	..	294,000	3.6	304,600	41.5	13.34
" 26, V.	14.8	4.625	0.6*	12	Throughout	..	..	297,000	3.6	307,700	41.2	13.11
" 27, IV.	15.6	10.13	..	5	30	..	..	273,000	..	273,000	40.4	14.49
1883.												
Jan. 8, I.	14.4	5.42	0.59	1	15	25	3	317,000	2.5	324,920	41.6	12.54
" 8, II.	14.7	4.85	0.55	5	20	53	11	504,000	2.8	518,100	41.3	7.81
" 8, III.	14.8	4.85	0.56	10	Throughout	75	30	546,000	2.9	561,800	41.2	7.18
" 10, VI.	14.0	4.625	0.65	5	Throughout	73	18	368,000	4.2	383,500	42.0	10.73
" 20, VII.	16.1	4.815	0.53	4	30	48	18	316,000	2.6	324,200	39.9	12.05
" 20, VIII.	16.3	4.84	0.63	6	33	50	28	340,900	3.7	353,500	39.7	11.00
" 8, II.	14.8	5.30	0.62	6	13	90	20	319,000	3.0	328,600	41.2	12.28
" 8, III.	15.0	5.32	0.70	11	29	180	120	310,700	3.7	322,200	41.0	12.47
											Total .	152.61
											Mean .	11.74

\* Approximately; the diameter was not accurately measured.

† The correction is only carried to four significant figures.

Our observations show that the black, at least in a cylindrical film, does not become thinner by lapse of time or by increase of area. In illustration of this point we may refer to Film III., Jan. 8, and Film III., Feb. 8.

Film III., Jan. 8.—The measurements began when the length of the black portion was about 11 millims., and were continued until the whole area of the film was black. The first measurement was made 45 minutes after the film was formed.

The resistance of the film between the needles

50 minutes after the film was formed	was	2.63	megohms
60	„	2.69	„
72	„	2.67	„

The mean of all the observations was 2.672.

Film III., Feb. 8.—This film, after being formed, was left to itself for an hour. At the end of this time about 15 millims. were black, and observations were at once commenced and were continued at intervals during two hours, at the end of which the film burst. The extreme length of the black was 29 millims.

After 1 <sup>h</sup> 20 <sup>m</sup>	the resistance was	1.644
2 <sup>h</sup> 20 <sup>m</sup>	„	1.607
2 <sup>h</sup> 50 <sup>m</sup>	„	1.680

The mean being 1.654.

Although in any given film the thickness of the black appears to be fairly constant, it will be seen from the above table that the thicknesses vary a good deal in different films. The most serious deviations from the mean occurred on Jan. 8 in Films II. and III., the values deduced from these being 7.82 and 7.19. We have no reason however to think the experiments on this day less trustworthy than others, as none of the precautions usually taken to ensure accuracy were neglected. Defective insulation at the needles, involving a deviation of the circuit, would have resulted in an increased and not a diminished value of the thickness. The fact that Film I. of the same date yielded the value 12.53, which does not differ much from the mean of the others, precluded the possibility that a different liquid had by some mischance been used. The number 12.53, however, had been derived from a single observation, and hence might appear to be less trustworthy than the others. To set all doubt on this point at rest, the specific resistance of the liquid used was without delay redetermined, and was, as was expected, found to be normal.

## II. *Optical experiments.*

The object of these experiments was, as has been already stated, the measurement of the mean thickness of a number of black soap films by an optical method.



A FRESNEL'S optical bank, of the pattern devised by Professor CLIFTON, was fitted with the apparatus necessary to produce interference bands by means of thick plates. The plates were specially prepared by Messrs. ELLIOTT Bros., and as their thickness was 18 millims., a considerable separation of the two interfering rays could be obtained. The angle between the two plates of the compensator could be altered, so that the sensitiveness of the instrument was under control and the angular motion of the whole compensator could be read off correct to 1' by means of a vernier. A small brass table was placed between the mirrors. It was carried by one of the sliders of the bank, and could be raised or lowered by rackwork. To this a brass plate, 460 millims. long by 50 millims. broad and about 3 millims. thick, was firmly clamped. It was furnished with two pairs of brass V-pieces, in which glass tubes about 400 millims. long and 18 millims. in internal diameter were placed. The ends of the tubes were ground and closed with plates cut from the same piece of plate glass. The requisite adhesion between the plates and tubes was obtained by slightly moistening the extremities of the latter.

All the different parts of the apparatus were marked, so that after each readjustment they could be readily replaced in the positions they previously occupied. With this precaution it was possible to remove the tubes and set them up again many times in succession without displacing the interference bands from the field of view.

The light employed was that of an oil lamp, and to prevent disturbance by heat from this, the apparatus was set up in front of a draught closet within which the lamp was placed. The window was then closed and the air surrounding the apparatus was thus completely cut off from that in the neighbourhood of the flame. A large screen of stout pasteboard prevented any light or radiant heat from the lamp or from the window of the draught closet falling upon any part of the apparatus except the first mirror and its immediate surroundings.

Before performing an experiment the interiors of the tubes were thoroughly moistened with the liquid to be used, into which one of the extremities of each of them was then dipped. On withdrawing them plane films were formed in the tubes, which, if they were then inverted, ran a little way down them. A second film could then be formed in each by again dipping the ends in the liquid, and so on until the tubes contained between 50 and 60 films apiece. Being thus charged they were placed in the V-pieces, closed with the glass plates, and left undisturbed until the films had thinned sufficiently to make an observation possible.

During the whole of this process, each film, with the exception of the first and last formed, was only directly exposed to the air for the few seconds which elapsed before the next in order was made. A considerable quantity of liquid was retained between the films, so that when the tubes were closed by the glass plates the whole of the air within them must speedily have become saturated. In this saturated space the films remained for at least half an hour if formed of plain soap solution, or at least an hour if formed of *liquide glycérique* before they were ready for observation. The

constitution of the films therefore cannot possibly have differed much from that of the liquids from which they were formed, and even if this were not so the changes in the refractive indices would have been too small to produce appreciable errors (see Phil. Trans., 1881, p. 485). When the films were thinning the field of view was traversed both by bands of colour due to the interference produced by the thin films, and by others due to the thick plates. To prevent confusion we propose to restrict the term interference *bands* to the first of these, and to call the second *fringes*. The instrument was so adjusted that the fringes were vertical and widely separated. Cross wires were introduced into the middle of the field of view, the compensator was placed in the vertical position and the central black fringe, exhibited when white light was used, was brought up to the vertical wire by slightly altering the orientation of the mirrors. A sheet of ruby glass was then interposed between the lamp and the mirrors, and the angles through which it was necessary to turn the compensator, to bring up to the vertical wire the fringes which were right and left of the central one, were measured. The mean of these values was taken as the angle corresponding to a wave length of red light, or according to our previous measurements to  $615 \times 10^{-6}$  millims. (Phil. Trans., 1881, p. 454).

The red glass having been removed, the "zero" or reading of the compensator when the central black fringe touched the vertical at its intersection with the horizontal cross wire was determined. It was then necessary to break a number of films in one of the tubes without in the least shaking or disturbing the apparatus. For this purpose one or two stout sewing needles had been enclosed with the films. A strong electromagnet was now used to move these, and a known number of films having thus been broken, the displacement of the black line was determined. In breaking the films care was always taken to leave if possible two or three unbroken at each end of the tube. Disturbance by the irruption of air from the outside, if the contact between the ends of the tubes and the glass plates was imperfect, was thus prevented.

If then

$T$  be the average thickness of a film,

$n$  the number of films broken,

$\mu$  the refractive index of the liquid,

$\lambda$  the wave-length of red light,

$\delta$  the angular displacement of the compensator necessary to restore the central fringe, after the rupture of the films, to the position it previously occupied ;  
and

$\alpha$  the angle (as above defined) corresponding to a wave-length of red light,

we have the equation

$$n(\mu - 1)T = \frac{\delta}{\alpha}\lambda.$$

When the tubes were placed in position the colours of the bright transmitted bands were, owing to the large number of films, very vivid, and the dark bands were very obscure. The fringes which had previously been made vertical were seen crossing the bright bands in a more or less sloping direction, but were completely lost in the darker portions of the field. When the films had thinned sufficiently to show by reflected light the white and black of the first order, the passage from the one tint to the other was, as is usual, so sudden as to appear discontinuous. The corresponding dark and light transmitted bands were very intense and the boundary between them was also perfectly definite and sharp. The fringes visible in the bright portion of the field (corresponding to the black seen by reflected light) were for the greatest part of their length vertical, but at first they often displayed a very considerable curvature at their lower extremities. In such cases they crossed the boundary at a very small angle and were lost in the dark band. The direction of the curvature was different on different occasions. The accompanying figure is a reproduction of a sketch on an



enlarged scale made at a time when the phenomenon was very marked. The cause of the curvature was evidently an increasing difference of thickness between the films in the two tubes in the neighbourhood of the limits of their black portions.

As all did not thin at precisely the same rate, this limit was in different films at different vertical elevations, and it might at first sight seem probable that the curvature was due to the fact that the boundaries between the white and black were in the one tube lower than in the other. The interfering rays in a given horizontal plane would thus, in the one case, traverse black films only, while in the other they would also pass through some white ones, and, as the number of these would increase rapidly as the vertical elevation of the plane diminished, a distortion of the fringes similar to that observed might have been produced.

If this had been the true explanation, we should have expected either that the intensity of the illumination would have increased gradually on passing from the dark to the bright transmitted bands, or that a marked discontinuity would have been observed in the curved fringes at the points where the number of the white films traversed increased. Neither of these phenomena were observed. The dark part of the field was very intense close to the boundary and the curves were unbroken.

Another hypothesis which would serve to explain the phenomenon is that the black portions of the films increased in thickness near the junction with the white, and that this increase was different in the two tubes. No evidence of any such

change of thickness was ever given by the electrical experiments, but it is, of course, possible that the behaviour of the cylindrical and plane films might in this respect be different.

Let  $n$  and  $n'$  be the number of the films in the two tubes. Let the mean thicknesses of the films in the first tube at the levels where the fringes crossed the boundary into the dark (transmitted) band, and where they became vertical, be  $t_1$  and  $t_2$ , and in the second let them be  $t_1'$  and  $t_2'$ . Then the difference of the paths of the interfering rays would be

$$\{(nt_1 - n't_1') - (nt_2 - n't_2')\}(\mu - 1) = \frac{\delta}{\alpha}\lambda$$

where  $\delta$  is the angular displacement of the compensator corresponding to the distance between the centre of one of the vertical fringes and the point where it cuts the boundary. Now since  $t_1$  and  $t_1'$  are greater than  $t_2$  and  $t_2'$  respectively,  $\lambda\delta/(\mu - 1)n\alpha$  is an inferior limit of the quantity  $t_1 - t_2$ .

The following table gives the data by which the value of this limit was determined on several occasions. Lengths are given in terms of millionths of a millimetre.

TABLE II.— $\lambda = 615$ ,  $\mu - 1 = 0.4$ .

$\delta/a$ .	$n$ .	$t_1 - t_2$ .
1.26	36	53.8
0.75	49	23.5
0.92	31	45.6
0.84	58	22.2

This table shows that a very considerable change of thickness is necessary to account for the phenomenon. If the average thickness of a black film be taken as  $12 \times 10^{-6}$  millims., the films in one tube at the boundary of the black must have been from 3 to 5 times as thick as elsewhere.

This explanation is not without its difficulties. The thickness of the "beginning of the black," when the proper correction for the refractive index is made, is, according to NEWTON'S tables,  $36 \times 10^{-6}$  millims., whereas one of our experiments (if we adopt the above hypothesis) shows the average thickness of the thickest black parts of the film to be  $(53.8 + 12) \times 10^{-6} = 65.8 \times 10^{-6}$  millims.

This discrepancy may, perhaps, be explained by the fact we have already referred to (Phil. Trans., 1881, p. 453) that measures on the diameters of NEWTON'S rings are of little value near the central black patch.

It is, however, difficult to understand why all the films in one tube should behave so differently from those in the other, while, if it be assumed that the difference is caused by a few films only, it becomes necessary to extend the limits of the black through an

improbable range. The phenomenon was always transient, and the whole of the curvature took place within a distance of one or two millimetres.

The measurement of the shift of the zero was a matter of some nicety. The field of view was scarcely large enough to make it convenient to take the readings when the vertical wire bisected the interval between two dark fringes. The observations were therefore made by causing them to touch the vertical cross wire, and, as their outline was irregular, it required some care to decide upon the particular phenomenon which should be called contact. Two readings might easily differ by a degree or more, *i.e.*, by from  $\frac{1}{3}$ th to  $\frac{1}{4}$ th of a wave length. As a rule the errors were much less, and the mean of five readings was always taken. Another reading as large or as small as the largest or smallest would hardly ever have altered the mean by more than 6', and we think the extreme possible error of the mean is not more than 10'. The most serious difficulty was due to the instability of the zero. The two tubes were mounted, as has been described, side by side, and the distance travelled by the interfering rays in unenclosed air was not more than 30 centims. Owing, however, either to slight changes in temperature or hygrometric state, or to some other undetected cause, the zero was continually moving. The motion was generally though not always in one direction. It was very variable in amount. Sometimes it was negligible, sometimes it produced a change of 4° or 5° in as many minutes. It is evident that the thickness of the films, given by any particular experiment, would be greater or less than the true value according as the motion of the zero was, or was not, in the same direction as that produced by the rupture of the films. The observed facts were in accordance with this, and the numbers obtained were generally larger or smaller than the mean according to the direction of the motion of the zero before the experiment. If therefore the motion remained constant during observations made on the two tubes, the results given by each would be oppositely affected, and the mean value would be correct. Even if, as was the case, it was impossible to ensure such constancy, the error of the mean would probably be much less than that of the individual observations. In all our experiments, therefore, the result of each was taken to be the mean of the numbers obtained by breaking the films first in one tube, and then in the other.

The following are the details of the last experiment performed with the *liquide glycérique*. The zero was on this occasion remarkably steady.

The ruby glass having been placed in front of the lamp, the angles through which it was necessary to turn the compensator to bring the fringes to the right and left of the central dark fringe into the position it previously occupied, were measured. These were always taken in the order—centre, left, centre, right, centre. The readings right and left were compared with the means of the two readings for the centre between which they were taken, to reduce the effect of any zero movement which might be in progress.

The angles given by two such sets of measures were

13° 41', 13° 31', 13° 25', and 13° 59'; mean 13° 39'.

The ruby glass was then removed and the experiment proceeded with as follows:—

Films counted.—Tube I., 59. II., 53.

Position of zero.—Five readings, when the central black fringe was in the standard position, gave

$1^{\circ} 50'$ ,  $1^{\circ} 58'$ ,  $1^{\circ} 46'$ ,  $1^{\circ} 45'$ , and  $2^{\circ} 13'$  respectively.

Films counted again.—Tube I., 58. II., 53.

Position of zero read once more  $1^{\circ} 37'$ .

Mean of six readings  $1^{\circ} 52'$ .

Films broken in Tube I., then counted

Tube I., 4. II., 53.

New position of zero determined five times

$6^{\circ} 42'$ ,  $6^{\circ} 11'$ ,  $6^{\circ} 58'$ ,  $7^{\circ} 12'$ ,  $7^{\circ} 15'$ .

Films counted and found unaltered.

Position of zero read once more  $7^{\circ} 10'$ .

Mean of six readings  $6^{\circ} 55'$ .

Films broken in Tube II.—A slight delay occurred here, as some of the films did not break easily. When the operation was completed they were counted again

Tube I., 4. II., 4.

New position of zero determined five times

$3^{\circ} 26'$ ,  $3^{\circ} 24'$ ,  $3^{\circ} 2'$ ,  $3^{\circ} 18'$ ,  $3^{\circ} 26'$ .

Mean of five readings  $3^{\circ} 19'$ .

Hence the zero shifted  $6^{\circ} 55' - 1^{\circ} 52' = 5^{\circ} 3' = 303'$  when 54 films were broken in Tube I., and  $6^{\circ} 55' - 3^{\circ} 19' = 3^{\circ} 36' = 216'$  when 49 films were broken in Tube II.

As therefore  $\alpha = 13^{\circ} 39' = 819'$ , and  $T = \delta\lambda/\alpha n(\mu - 1)$  we get from the first tube (in millionths of a millimetre)

$$T = 303 \times 615 / 819 \times 54 \times 0.4 = 10.5,$$

and from the second

$$T = 216 \times 615 / 819 \times 49 \times 0.4 = 8.3.$$

Mean value  $T = 9.4$ .

This result is less than usual. During the experiments on the first tube the zero was very steady, and the value obtained was almost exactly equal to the mean from all the experiments. Before the observations on the second tube, the zero showed a tendency to rise, and the slight delay which followed may have given time for a motion sufficient to reduce the second value to that actually found.

The following tables give the results of the experiments.

The films formed of plain soap solution did not last so well as those made of *liquide glycérique*. The numbers broken in the experiments are therefore smaller. Several

experiments failed, as too many films broke before they were ready for observation, or, as some slight disarrangement of the apparatus was observed, which would invalidate the observations.

Two observations on the soap solutions gave results so widely different from the rest that they are omitted as probably incorrect. With these exceptions all the results obtained are included in the tables.

Column I. gives the number of minutes which elapsed after the tubes were set up, before the films were broken in tubes 1 and 2 respectively.

Column II. gives the number of films broken in each tube.

Column III. the average thickness of a film in millionths of a millimetre.

TABLE III.—Soap Solution.

I.		II.		III.
1.	2.	1.	2.	
40	50	21	30	14.4
30	40	32	46	11.7
160	180	34	29	11.9
30	35	23	26	11.4
90	95	36	33	10.6
37	40	17½*	18½*	11.8
35	45	17	13	13.2†
33	40	24	20	10.3†
33	40	34½*	32	13.4
				Mean 12.1

TABLE IV.—Liquide Glycérique.

I.		II.		III.
1.	2.	1.	2.	
87	93	35½*	31	10.6
85	93	27	30	10.2
80	85	28	32	12.5
60	63	52	51	10.7
65	70	50	49	10.2
75	82	49	45	11.0
65	63	54	49	9.4
				Mean 10.7

It will be observed that there is no relation between the time which had elapsed since the formation of the films and their thickness.

\* Films broke during measurements.

† Zero very unsteady.

III. *Summary of results.*

We are now able to sum up the results of our experiments. Observations have been made upon three liquids, the properties of which are given in the following table.

Date of observation.	Nature of liquid.	Percentage of $\text{KNO}_3$ in water of solution.	Refractive index.	Specific resistance at $15^\circ$ .
1877	Liquide glycérique . . . . .	3	1.395	214
1883	” . . . . .	5	1.397	166
”	Soap solution without glycerine .	2.88	1.337	41

The first and third liquids were examined electrically; the former by the galvanometer, the latter by the electrometer method. The second and third liquids were examined by the optical method.

In no case was there any evidence, when the liquid films were cylindrical, of a change in the thickness of the black portion. In the case of the plane films formed in the tube, the optical observations indicated an increase in the thickness of the black near its lower extremity. The evidence on this head is however doubtful. Whenever the area of the black portion of the film became somewhat extended the phenomenon, which may indicate a difference between the thicknesses of its various parts, disappeared. There seems, therefore, no doubt that in the case of films formed as in our experiments, the black portions assume a particular thickness either at, or soon after, their first formation, and that this remains unaltered either by lapse of time or by alterations in the dimensions of the black area.

Although, however, our observations prove that this thickness is practically constant for any one film, they indicate considerable variations in its magnitude for different films. The differences between the numbers given by the optical method are perhaps not much in excess of the probable error of experiment, but in the case of the electrical observations they far exceed it. They may be partly due to slight changes in constitution; but the following reasons negative the supposition that this is the only, or indeed an important, cause.

In the first place, the constitution of a *liquide glycérique* is more difficult to maintain unaltered than that of a soap solution. It is, however, in films formed with the latter that the greatest apparent variations in thickness occur. This, on the other hand, is in accord with the fact that films formed without glycerine are, as is proved by the colour phenomena they display, more uncertain and irregular in their behaviour than those made of the standard solution. Again, if a change of constitution took place, we should probably have detected it by progressive changes in the calculated thickness, which would in reality have been due to alterations



in the specific resistance. Finally, the absolute constancy of the hygrometer and thermometer seem to preclude the possibility of any considerable change of constitution even in a black film. On the whole then we think that the thickness of the black portions is really different in different films. These differences are in general relatively small. According to NEWTON, the thickness of the "beginning of the black" would be  $36 \times 10^{-6}$  and  $37 \times 10^{-6}$  millims. for the *liquide glycérique* and the soap solution respectively. Apart, therefore, from our previous knowledge of molecular magnitudes, any thickness less than these would be equally probable; but the following table of the results obtained proves that both methods concur in showing that the average thickness is about  $11.6 \times 10^{-6}$  millims., while the electrical experiments show that the "probable error," or divergence of the thickness of any given film from the mean value, is  $1.2 \times 10^{-6}$  millims.

TABLE V.

Liquide glycérique.		Soap solution.	
Electrical method (1877).	Optical method (1883).	Electrical method.	Optical method.
12.2	10.6	12.32	14.4
11.9	10.2	13.32	11.7
12.0	12.5	13.36	11.9
11.6	10.7	13.13	11.4
12.0	10.2	14.46	10.6
..	11.0	12.58	11.8
..	9.4	7.82	13.2
..	..	7.19	10.3
..	..	10.74	13.4
..	..	12.07	..
..	..	11.01	..
..	..	12.29	..
..	..	12.46	..
Mean 11.9	10.7	11.74	12.1

Into the causes of the variations in the thickness of different black films we do not now propose to enquire. The above observations prove that they are comparatively small. The fact that the boundary between the black and coloured portions of a film is always well defined, and that there must therefore be a very sudden change of thickness in passing from the one to the other seems to point to a region of instability in the neighbourhood of the beginning of the black, such that films, the thicknesses of which are included within it, thin very rapidly to below its lower limit. Very short-lived films made of ordinary soap and water sometimes exhibit a grey tint, intermediate to the white and black of the first order, but persistent films, as far as our experience goes, never do. The foregoing observations seem to fix the limit of this

region at about  $14.5 \times 10^{-6}$  millims., and to prove that films generally thin to below but not to very much below it, so that the thickness of black soap films rarely differs from  $11.6 \times 10^{-6}$  millims., by more than one or two millionths of a millimetre. It has never been observed to fall below  $7.2 \times 10^{-6}$  millims., and thus, without attaching any theoretical importance to the term, this thickness seems to be practically the *limiting thickness* of such liquid films as we have studied.

We conclude by summarizing the results arrived at in this and our former papers with respect to black soap films :

(1.) Persistent soap films, which thin sufficiently to exhibit the black of the first order of NEWTON'S rings, invariably display an apparent discontinuity in their thickness at the boundary of the black and coloured portions.

(2.) The whole of the black region at the time of or very soon after its formation is of a uniform thickness.

(3.) This thickness remains unaltered in any film, whether the coloured parts of the film are thinning or thickening, increasing or diminishing in extent.

(4.) It is different for different films, but no connexion has been traced between its magnitude and the time which elapsed between the first formation of the film, and the first appearance of the black, or between either and the time of observation.

(5.) The mean values of this thickness are the same to within a fraction of a millionth of a millimetre, whether the films be plane or cylindrical, in contact with metal or with glass, formed of soap solution alone or with the addition of more than two-thirds of its volume of glycerine.

(6.) Two completely independent methods of measuring the thickness of the black portions of the films give concordant results.

(7.) The mean value of the thickness, calculated by giving equal weight to the results of the electrical and optical experiments, is  $11.6 \times 10^{-6}$  millims., the extreme values being  $7.2 \times 10^{-6}$  and  $14.5 \times 10^{-6}$  millims.

The smaller of these quantities is therefore a limiting thickness to which a soap film in air saturated with the vapour of the liquid from which it is formed rarely attains, and below which none of the films observed by us have thinned.

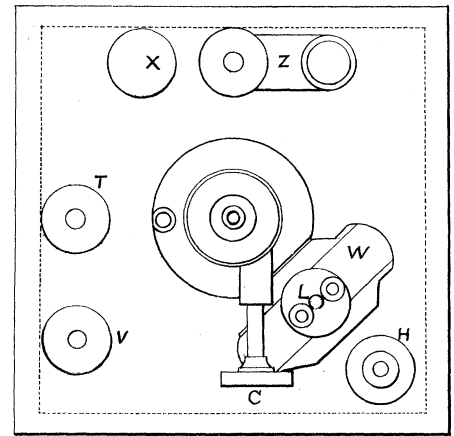
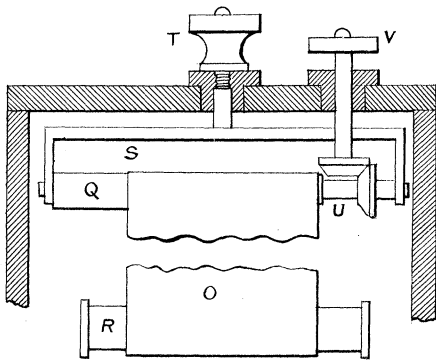

Fig. 3.

Fig. 1.

